

# FRE153 \_REV10



## FRE153/FREE IDEAS

AISI 316/L STAINLESS STEEL

Soffione doccia orientabile con estremità in Delrin® e getto a cascata





*Adjustable shower head with Delrin® end and waterfall jet*

CEA DESIGN STUDIO

 Staffa ausiliaria per cartongesso / fibrogesso  
*Auxiliary bracket for plasterboard / fiber-board structures*

 Staffa ausiliaria per cartongesso / fibrogesso  
*Auxiliary bracket for plasterboard / fiber-board structures*

### MANUTENZIONE / MAINTENANCE

|                              |   |   |
|------------------------------|---|---|
| NON UTILIZZARE<br>DO NOT USE |  | acido clorico e muriatico<br><i>chloric and muriatic acid</i> |
|                              |  | acido fluoridrico<br><i>hydrofluoric acid</i>                 |
|                              |  | ipoclorito di sodio<br><i>chlorine bleach</i>                 |
| UTILIZZARE<br>TO USE         |  | sapone a PH neutro<br><i>neutral PH soap</i>                  |

Questi disegni sono proprietà di CEADESIGN SRL s.u. pertanto non potranno essere utilizzati e/o comunicati a terzi, anche in forma parziale, senza preventiva autorizzazione. CEADESIGN SRL s.u. si riserva il diritto di apportare modifiche ai disegni al fine di migliorare il prodotto.

*CEADESIGN SRL s.u. has the property rights on these drawings, therefore they cannot be used and/or transferred to third party, even in partial form, without any prior authorization. Furthermore CEADESIGN SRL s.u. reserves the right to apply any change to these drawings in order to upgrade the product.*



ceadesign.it

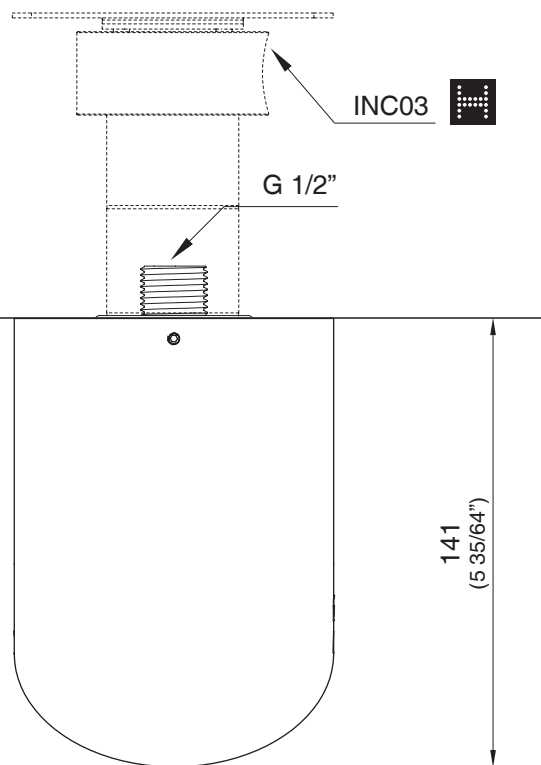
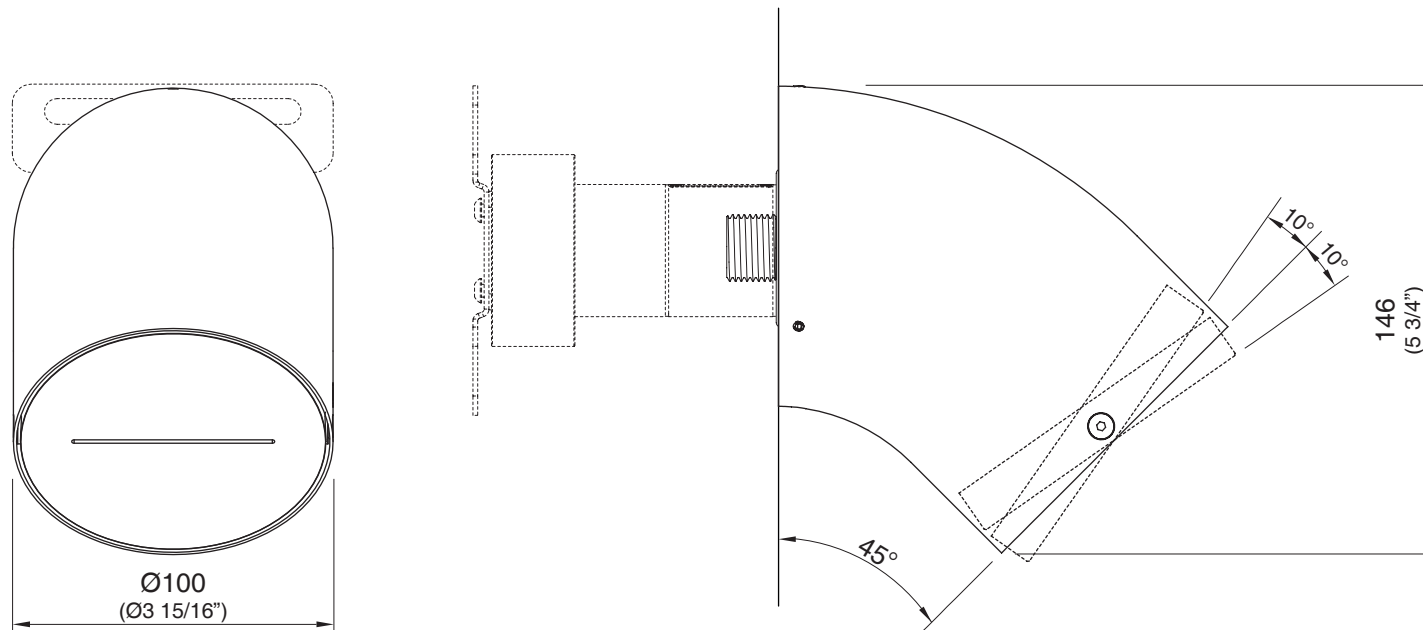

### INCLUDED EXTENSION

G 1/2"



GETTO A CASCATA / WATERFALL JET

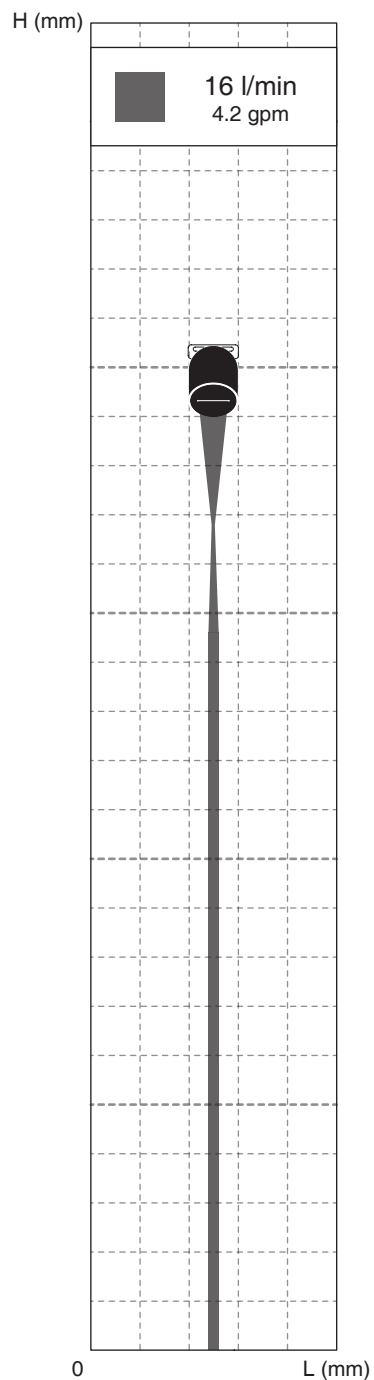
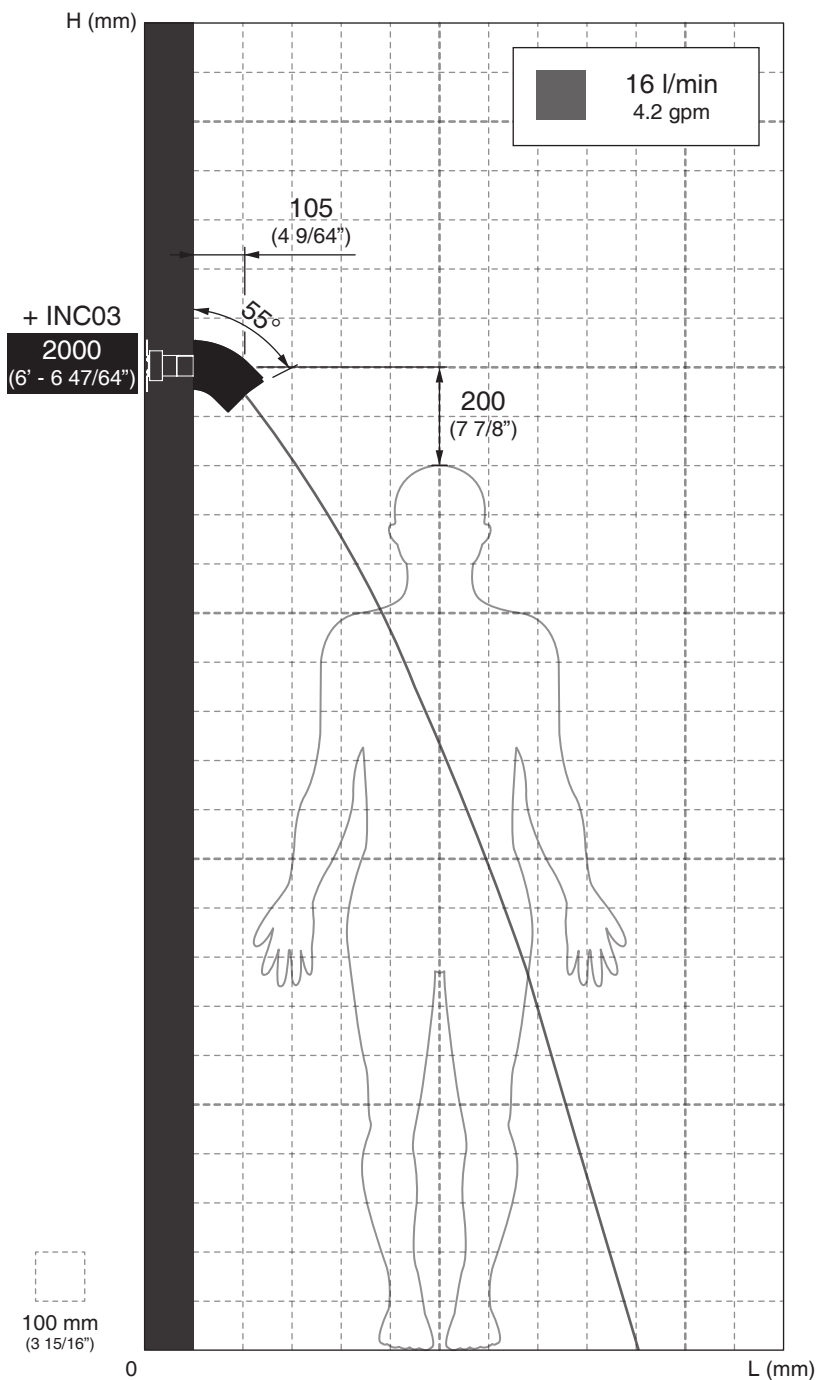

# FRE153

\_REV10

## AVVERTENZE DI INSTALLAZIONE

L'altezza ottimale di installazione del prodotto si determina in base all'altezza dell'utente.  
La rappresentazione ha valore puramente indicativo.

## INSTALLATION WARNINGS

Each individual product has to be installed and adjusted to suit the user's height.  
The representation is purely indicative.

## INSTALLATIONS WARNING

Die optimale Anbringungshöhe der einzelnen Produkte ist abhängig von der Körpergröße der Benutzer.  
Die Zeichnung ist rein indikativ.

## ADVERTENCIAS DE INSTALACIÓN

La altura de colocación ideal de cada producto se determina conforme a la altura de la persona.  
La representación es indicativa.

## AVERTISSEMENTS D'INSTALLATION

La hauteur optimale de l'emplacement du produit est à déterminer selon la taille de la personne.  
La représentation est purement indicative.

Le portate indicate sono alla pressione consigliata di 3 bar  
*The indicated flow rates are at the recommended pressure of 3 bar*

## PORTATA MASSIMA / MAXIMUM FLOW RATE \*

Getto a cascata / Waterfall jet  
16 l/min / 4.2 gpm

\* Il flusso è determinato dalla portata del comando abbinato  
*The flow is determined by the range of the combined control*

**CEA**

GETTO A CASCATA / WATERFALL JET

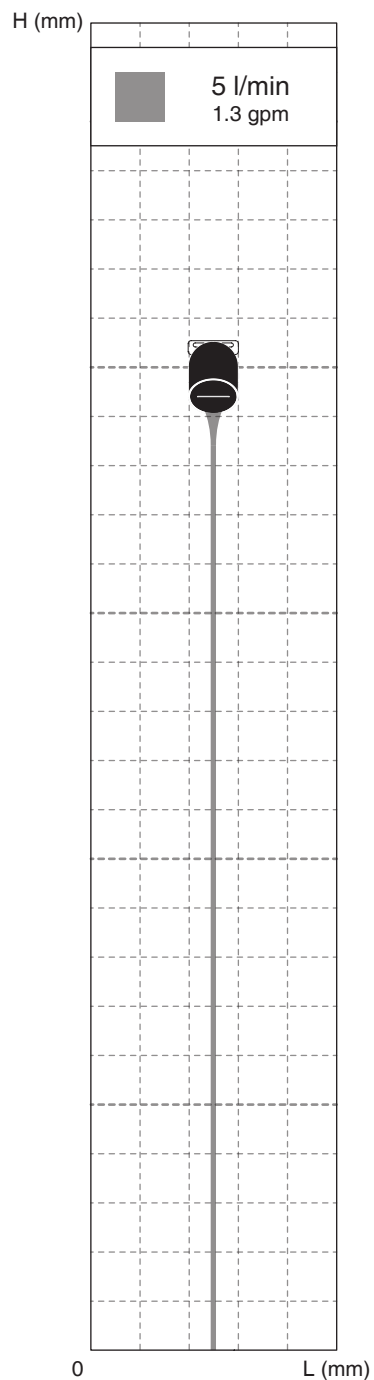
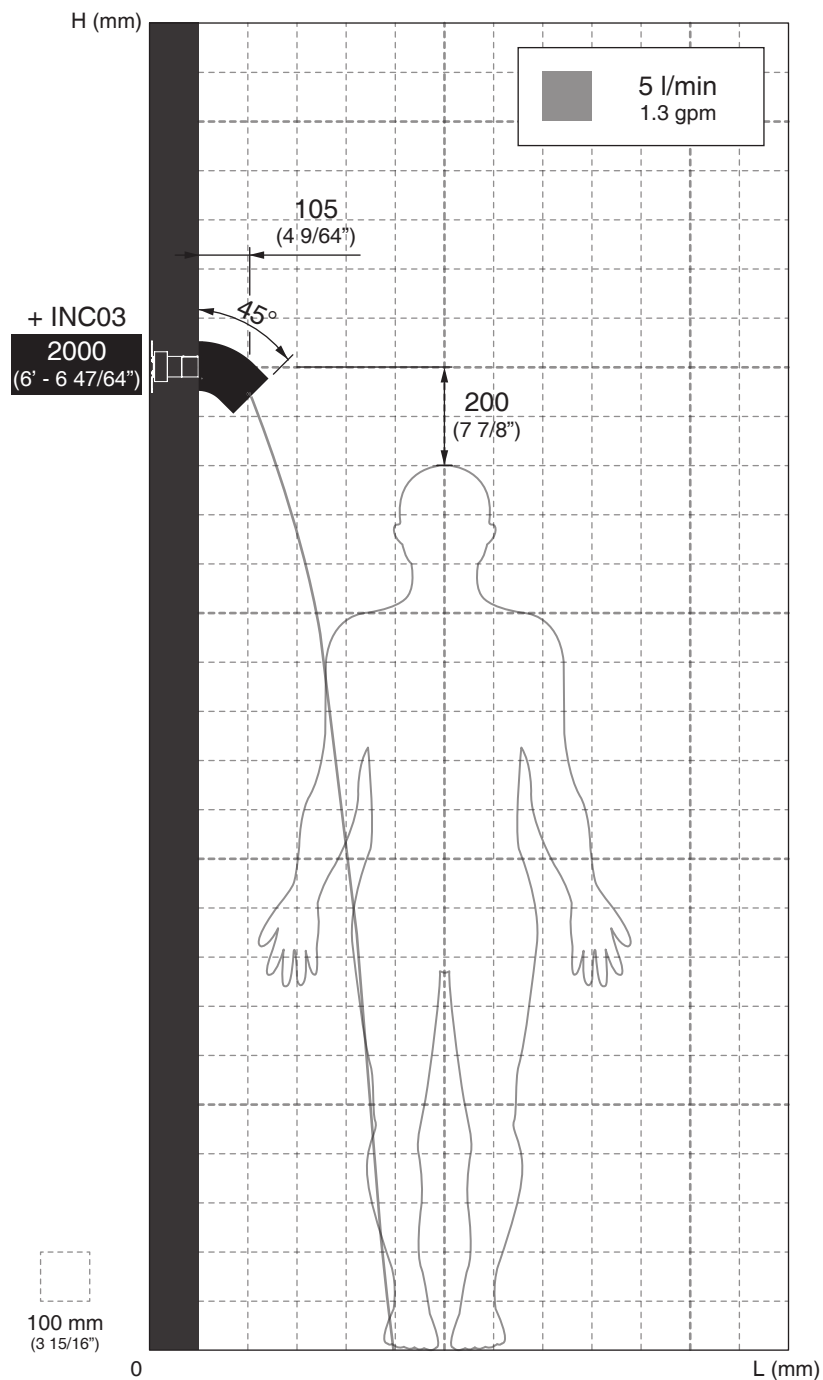

# FRE153

\_REV10

## AVVERTENZE DI INSTALLAZIONE

L'altezza ottimale di installazione del prodotto si determina in base all'altezza dell'utente.  
La rappresentazione ha valore puramente indicativo.

## INSTALLATION WARNINGS

Each individual product has to be installed and adjusted to suit the user's height.  
The representation is purely indicative.

## INSTALLATIONS WARNING

Die optimale Anbringungshöhe der einzelnen Produkte ist abhängig von der Körpergröße der Benutzer.  
Die Zeichnung ist rein indikativ.

## ADVERTENCIAS DE INSTALACIÓN

La altura de colocación ideal de cada producto se determina conforme a la altura de la persona.  
La representación es indicativa.

## AVERTISSEMENTS D'INSTALLATION

La hauteur optimale de l'emplacement du produit est à déterminer selon la taille de la personne.  
La représentation est purement indicative.

Le portate indicate sono alla pressione consigliata di 3 bar  
*The indicated flow rates are at the recommended pressure of 3 bar*

## PORTATA MINIMA / MANIMUM FLOW RATE \*

Getto a cascata / Waterfall jet  
5 l/min / 1.3 gpm

\* Il flusso è determinato dalla portata del comando abbinato  
*The flow is determined by the range of the combined control*

## SU RICHIESTA / ON DEMAND

 Riduttore di portata / Flow regulator  
5 l/min / 1.3 gpm

**CEA**

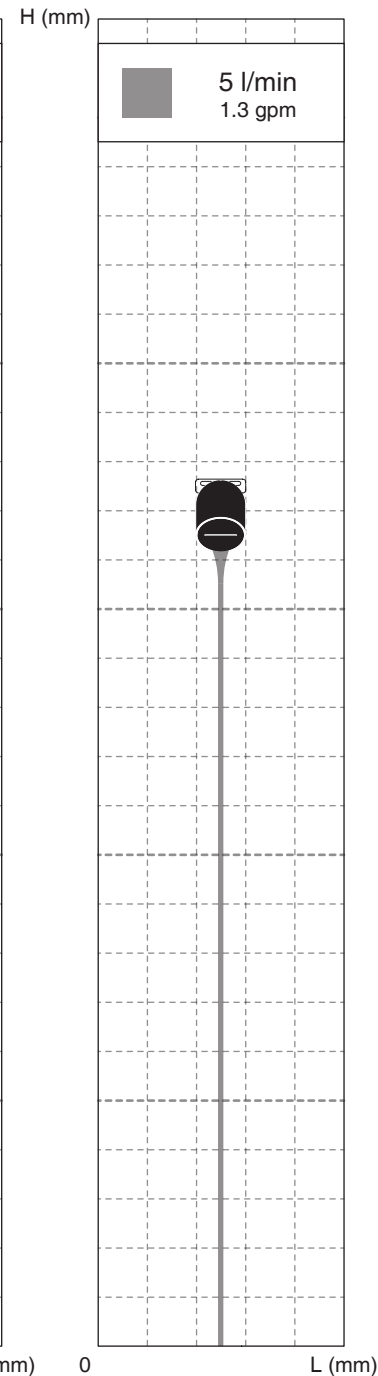
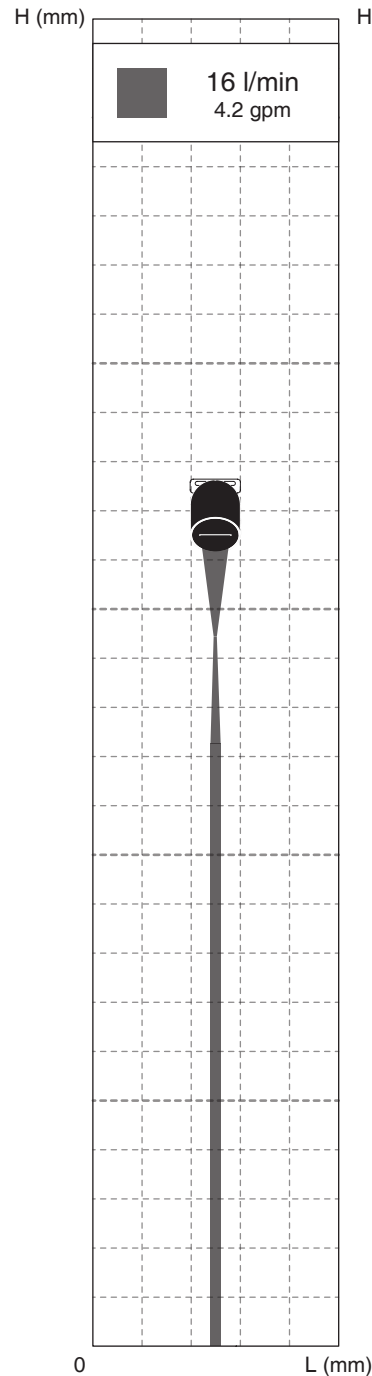
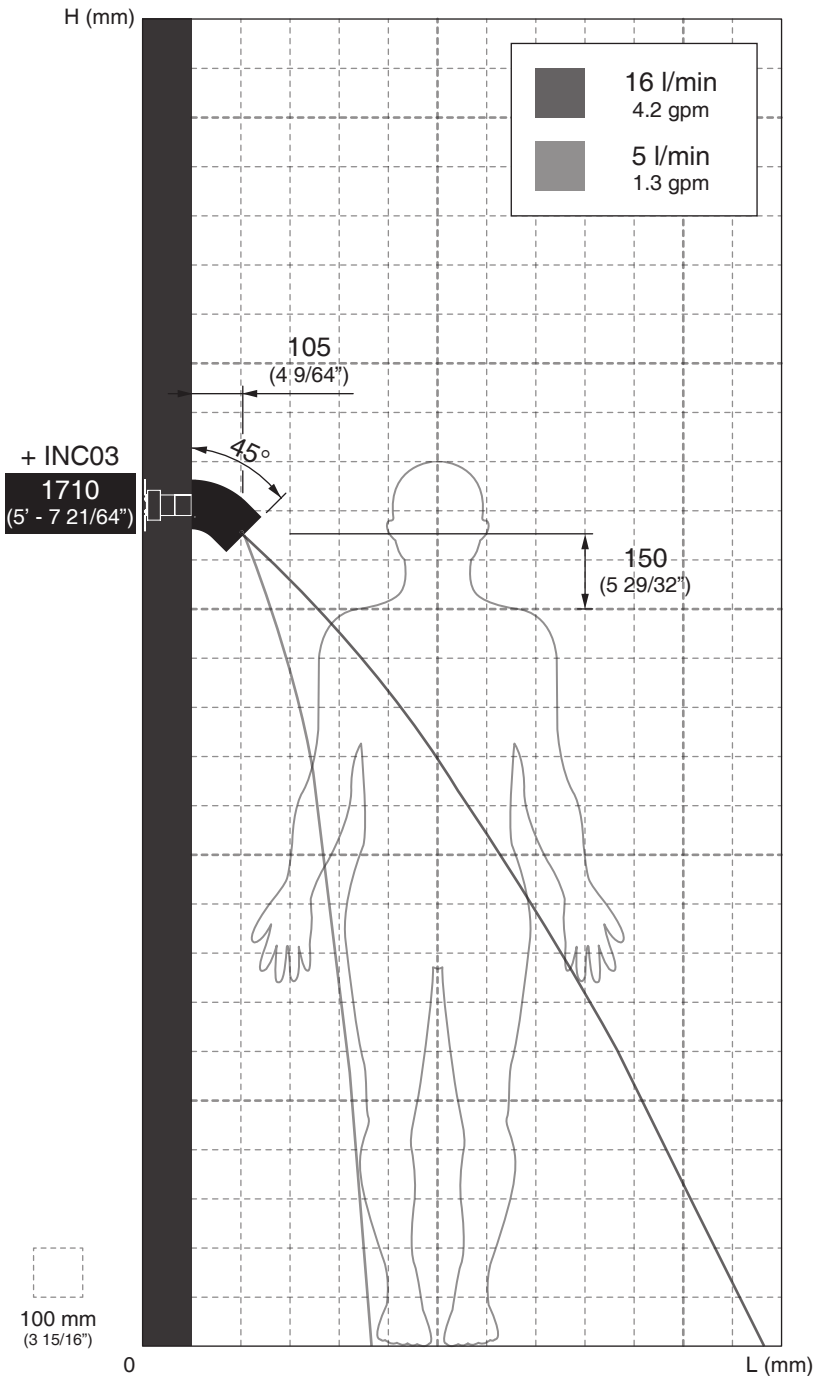

# FRE153

\_REV10

## AVVERTENZE DI INSTALLAZIONE

L'altezza ottimale di installazione del prodotto si determina in base all'altezza dell'utente.  
La rappresentazione ha valore puramente indicativo.

## INSTALLATION WARNINGS

Each individual product has to be installed and adjusted to suit the user's height.  
The representation is purely indicative.

## INSTALLATIONS WARNING

Die optimale Anbringungshöhe der einzelnen Produkte ist abhängig von der Körpergröße der Benutzer.  
Die Zeichnung ist rein indikativ.

## ADVERTENCIAS DE INSTALACIÓN

La altura de colocación ideal de cada producto se determina conforme a la altura de la persona.  
La representación es indicativa.

## AVERTISSEMENTS D'INSTALLATION

La hauteur optimale de l'emplacement du produit est à déterminer selon la taille de la personne.  
La représentation est purement indicative.

Le portate indicate sono alla pressione consigliata di 3 bar  
*The indicated flow rates are at the recommended pressure of 3 bar*

## PORTATA MASSIMA / MAXIMUM FLOW RATE \*

Getto a cascata / *Waterfall jet*

16 l/min / 4.2 gpm

## PORTATA MINIMA / MANIMUM FLOW RATE \*

Getto a cascata / *Waterfall jet*

5 l/min / 1.3 gpm

\* Il flusso è determinato dalla portata del comando abbinato  
*The flow is determined by the range of the combined control*

## SU RICHIESTA / ON DEMAND



Riduttore di portata / *Flow regulator*  
5 l/min / 1.3 gpm

**CEA**

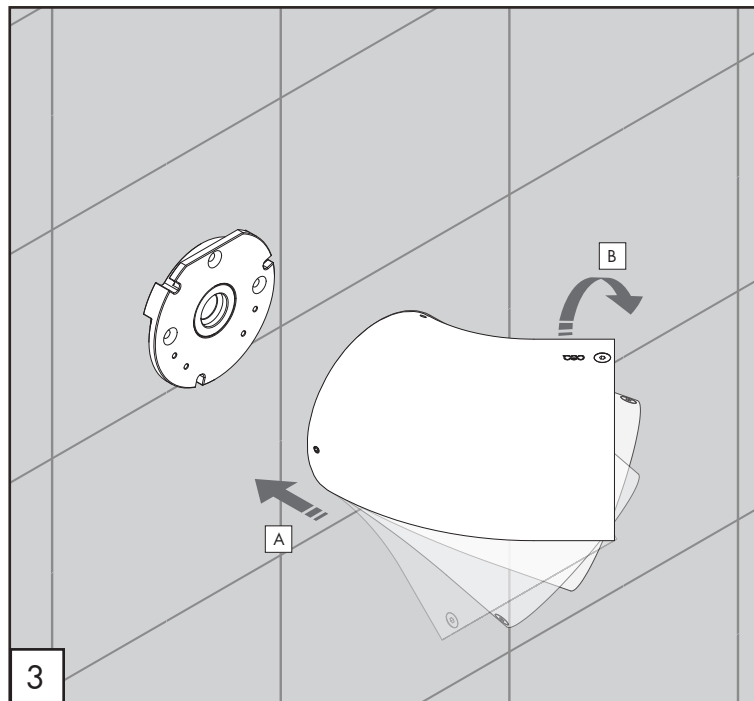
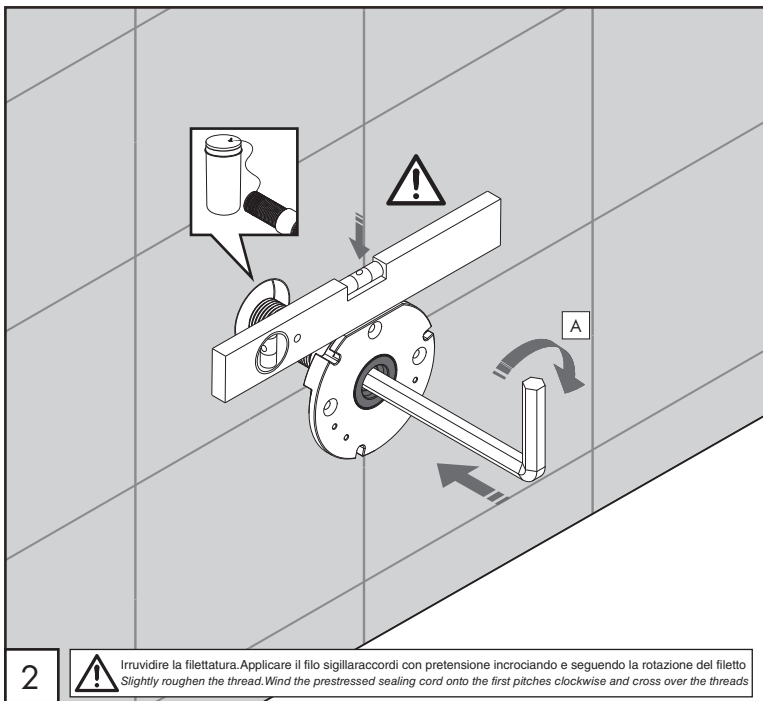
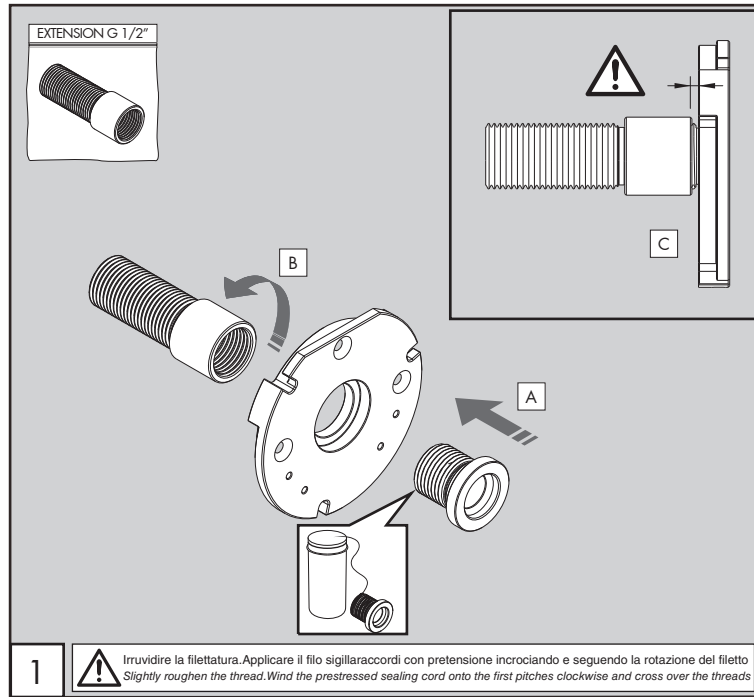
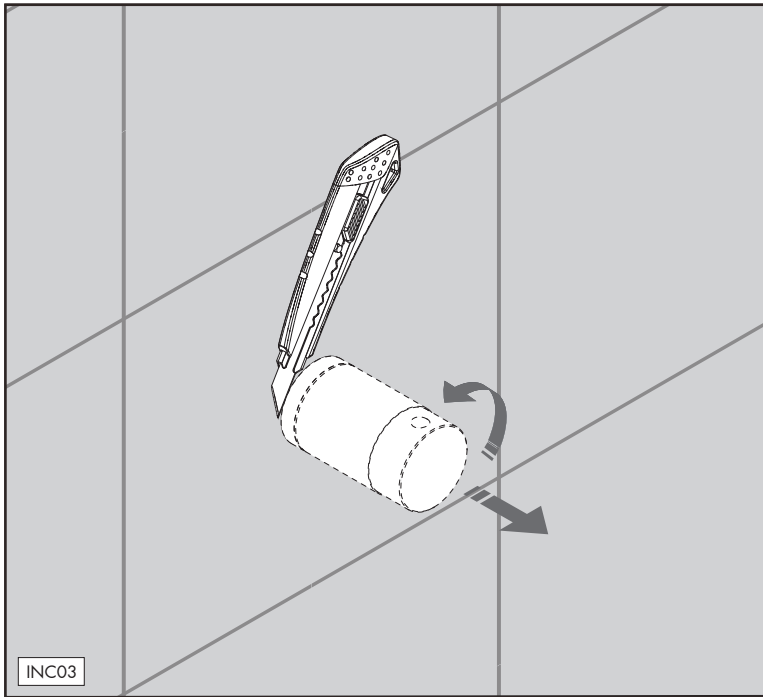

# FRE153 \_REV10

## AVVERTENZE TECNICHE

Risciacquare bene le tubazioni prima del montaggio ed evitare sbalzi di pressione.

In caso di pressioni statiche superiori a 5 bar si raccomanda l'installazione di un riduttore di pressione per evitare danni al soffione.

## TECHNICAL WARNINGS

The pipes have to be rinsed thoroughly before installation to avoid pressure differences.

Use of a pressure reducer when static pressure is higher than 5 bar to avoid damage of the shower head.

## TECHNISCHE WARNUNG

Spülen Sie die Leitungen vor dem Einbau und verhindern Sie Wasserdruckwechsel.

Wenn Wasserdruck größer als 5 bar ist, bitte reduzieren Sie den Systemdruck, um Beschädigung der Kopfbrause zu verhindern.

## ADVERTENCIA TÉCNICA

Purgar bien las tuberías antes de la instalación y evitar cambios bruscos de presión.

En caso de presión estática mayor de 5 bar, se recomienda el uso de un adaptador de presión para evitar daños en el rociador.

## ADVERTISSEMENTS TECHNIQUES

Rincer les tuyaux avant l'installation. Eviter grandes différences de pression.

En cas de pressions statique de plus de 5 bar, nous vous recommandons d'installer un réducteur de pression pour éviter des dommages à la douche de tête.

## TEMPERATURA DI ESERCIZIO / WORKING TEMPERATURE

max. 70 °C  
max. 158 °F

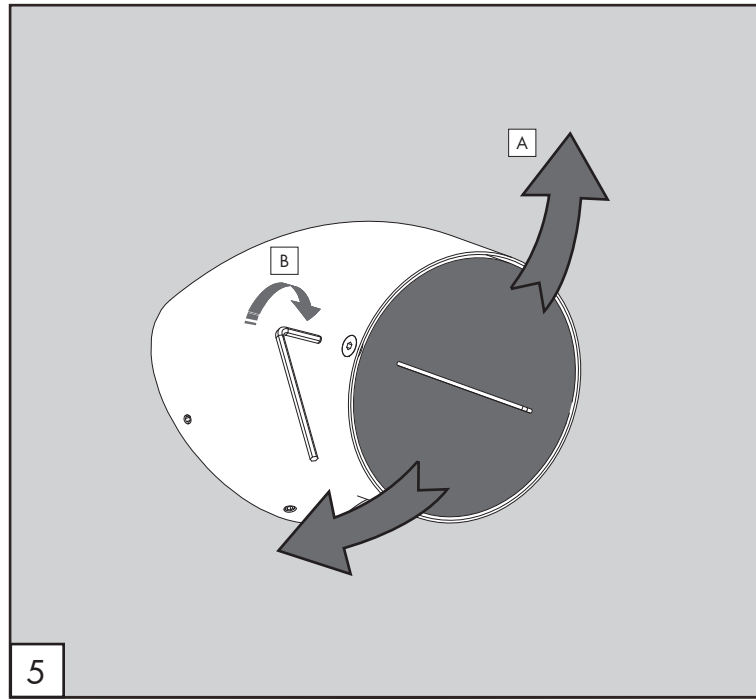
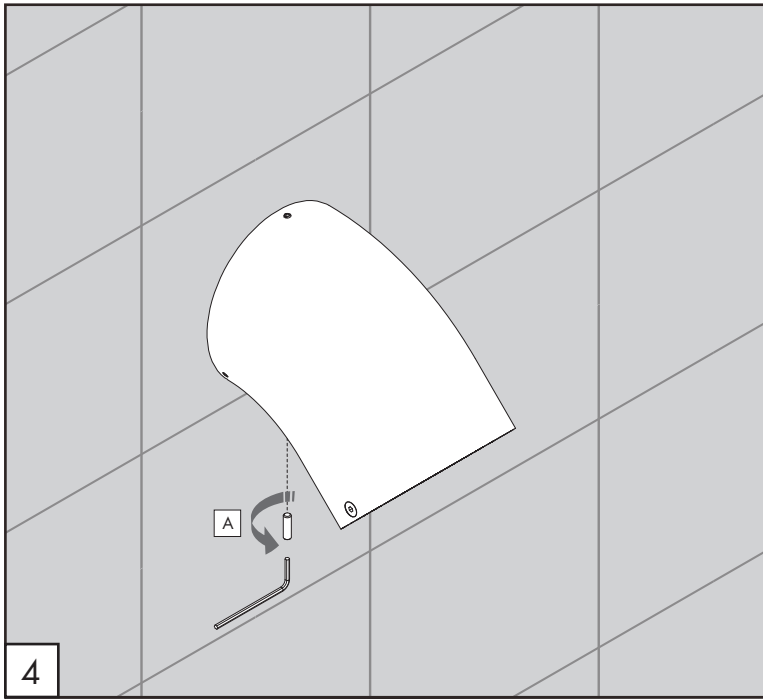

# FRE153

\_REV10

## RICAMBI / SPARE PARTS

|         |   |
|---------|---|
| RICF058 | Flessibile / Hose                       |
| RICS085 | Flangia di fissaggio / Fastening flange |
| RICS098 | Testa soffione / Head shower disk       |
| RICT007 | Raccordo / Fitting                      |

## SU RICHIESTA / ON DEMAND

|         |                                       |                   |
|---------|---------------------------------------|-------------------|
| RICA083 | Riduttore di portata / Flow regulator | 5 l/min / 1.3 gpm |
|---------|---------------------------------------|-------------------|

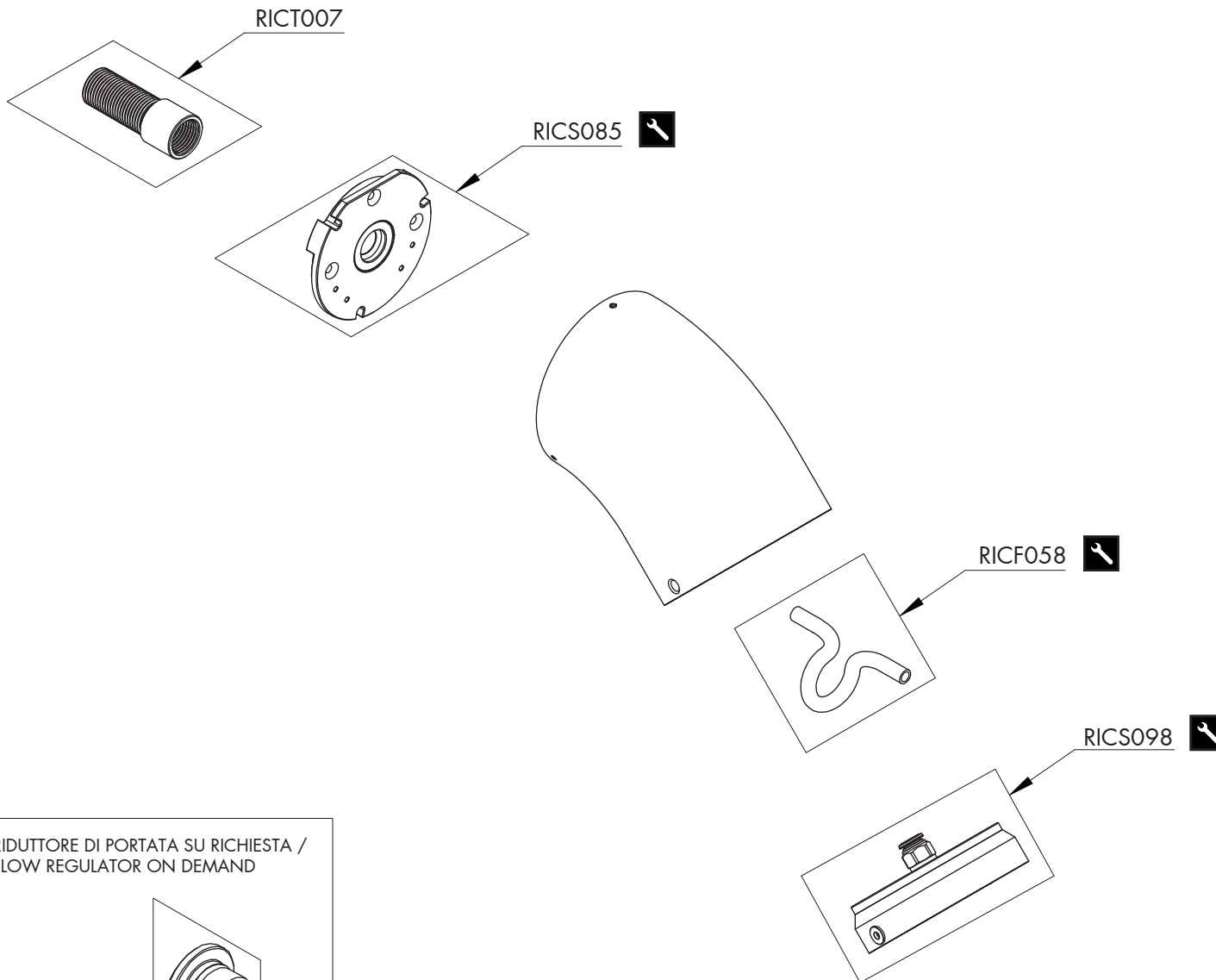

RIDUTTORE DI PORTATA SU RICHIESTA /  
FLOW REGULATOR ON DEMAND

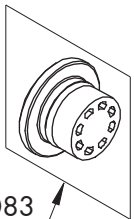

  RICA083



Conservare gli strumenti inclusi nel prodotto e utilizzati per l'installazione perché riutilizzabili per i ricambi.

Please, keep the tools included in the item pack and employed for its installation, to re-used them for the spare parts.

Die Werkzeuge, die Sie für die Installation des Produktes benutzt haben, bitte aufbewahren, da sie auch für die Installation der Ersatzteile benutzt werden können.

No tirar las herramientas incluidas en el producto y usadas durante la instalación puesto que se pueden reutilizar para los recambios.

Veuillez conserver les outils inclus dans la boîte du produit et employés pour son installation, parce que réutilisables pour les pièces de rechange.

## LEGENDA / LEGEND

### ICONE / ICONS



Riduttore di portata a risparmio idrico  
Water saving flow regulator



Utensile incluso nel ricambio  
Tool included in spare part

# CEQ