



UCS09   Considerare la posizione destra o sinistra della maniglia / Please consider the position right or left of the handle



INCLUDED ADAPTER
G 3/8" - G 1/2"

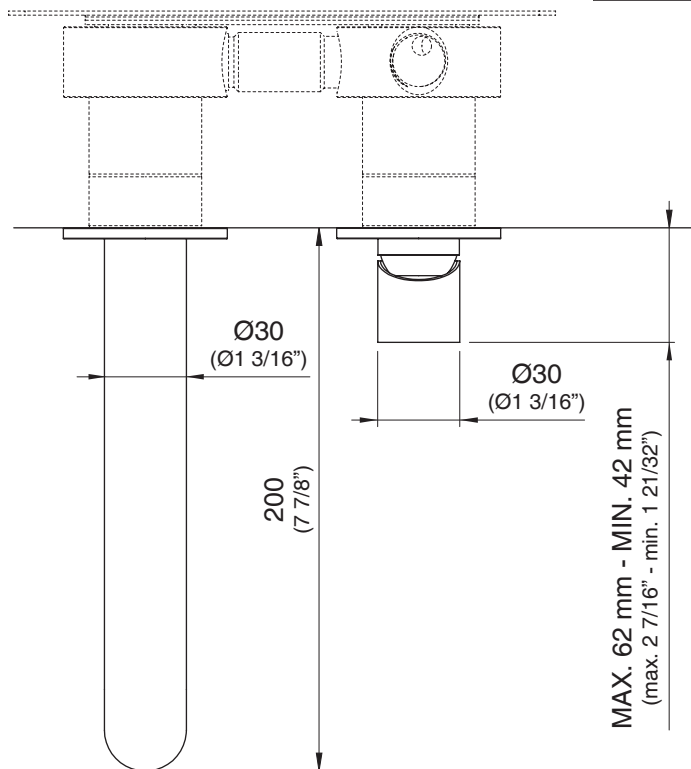

CAR10_REV11



CAR10/CARTESIO

AISI 316/L STAINLESS STEEL

Miscelatore a parete con bocca di erogazione

Wall mounted mixer with spout

CMP DESIGN







 Portata aeratore 5 l/min / 1.3 gpm, risparmio idrico
Flow rate aerator 5 l/min / 1.3 gpm, water saving

 Prodotto che necessita di parte incasso
Product that needs built-in part

 Staffa ausiliaria per cartongesso / fibrogesso
Auxiliary bracket for plasterboard / fiber-board structures

MANUTENZIONE / MAINTENANCE

NON UTILIZZARE DO NOT USE		acido clorico e muriatico chloric and muriatic acid
		acido fluoridrico hydrofluoric acid
		ipoclorito di sodio chlorine bleach
UTILIZZARE TO USE		sapone a PH neutro neutral PH soap

Questi disegni sono proprietà di CEADESIGN SRL s.u. pertanto non potranno essere utilizzati e/o comunicati a terzi, anche in forma parziale, senza preventiva autorizzazione. CEADESIGN SRL s.u. si riserva il diritto di apportare modifiche ai disegni al fine di migliorare il prodotto.

CEADESIGN SRL s.u. has the property rights on these drawings, therefore they cannot be used and/or transferred to third party, even in partial form, without any prior authorization. Furthermore CEADESIGN SRL s.u. reserves the right to apply any change to these drawings in order to upgrade the product.

CEA

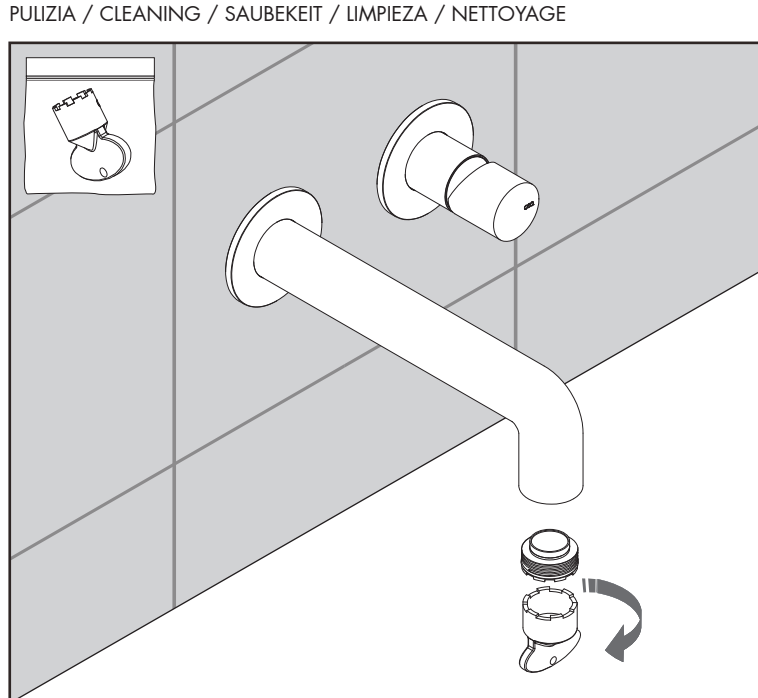
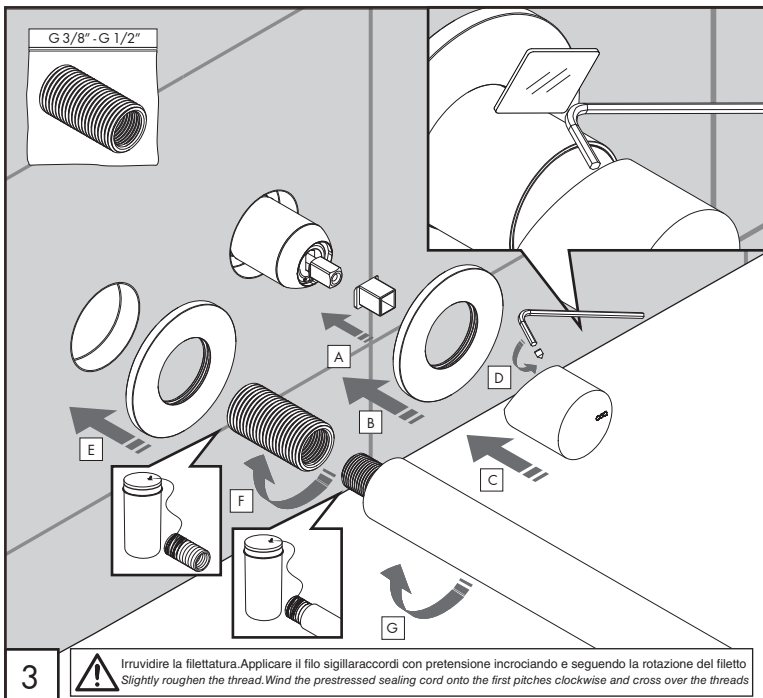
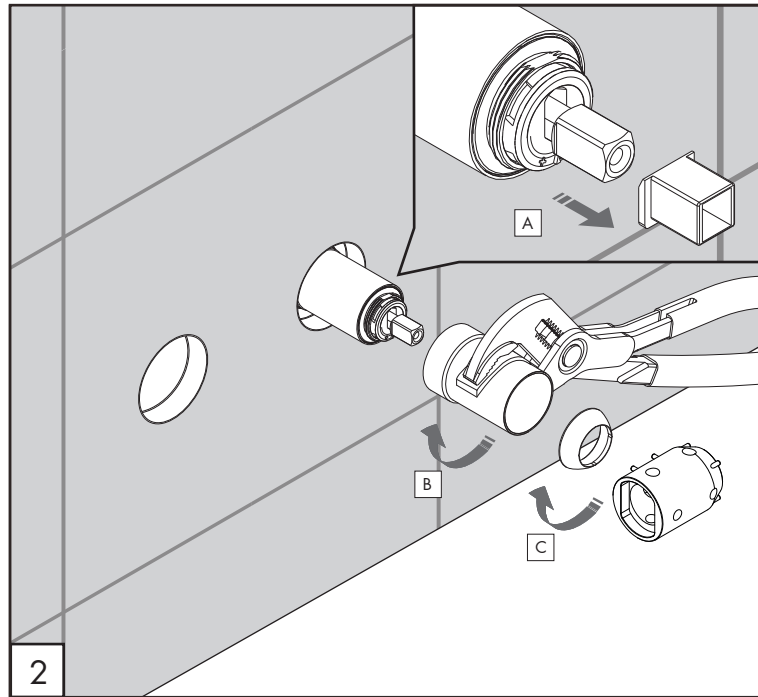
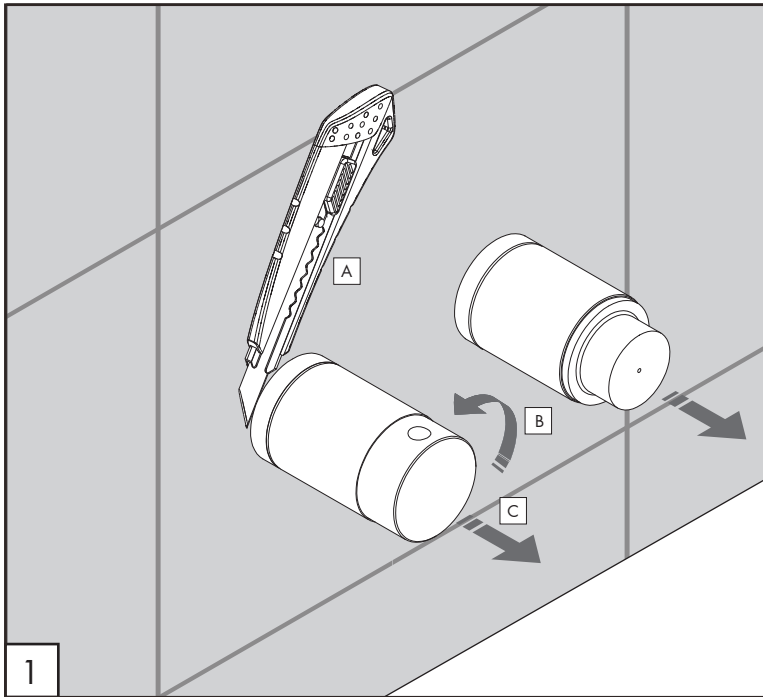

CAR10

_REV11



AVVERTENZE TECNICHE

Risciacquare bene le tubazioni prima del montaggio ed evitare sbalzi di pressione fra i raccordi d'acqua fredda e d'acqua calda. In caso di pressioni statiche superiori a 5 bar si raccomanda l'installazione di un riduttore di pressione per evitare danni alla cartuccia.

TECHNICAL WARNINGS

The pipes have to be rinsed thoroughly before installation. Avoid pressure differences between hot and cold water supply. Use of a pressure reducer when static pressure is higher than 5 bar to avoid damage of the cartridge.

TECHNISCHE WARNUNG

Spülen Sie die Leitungen vor dem Einbau und verhindern Sie Wasserdruckwechsel zwischen kalt und warm Wasserverbindungen. Wenn Wasserdruck größer als 5 bar ist, bitte reduzieren Sie den Systemdruck, um Beschädigung der Kartusche zu verhindern.

ADVERTENCIA TÉCNICA

Los tubos tienen que ser enjuagados a fondo antes de la instalación. Evitar grandes diferencias de presión entre las conexiones de agua caliente y fría. En caso de presión estática mayor de 5 bar, se recomienda el uso de un adaptador de presión para evitar daños en el cartucho.

ADVERTISSEMENTS TECHNIQUES

Rincer les tuyaux avant l'installation. Eviter des grandes différences de pression entre l'eau froide et chaude. En cas de pressions statique de plus de 5 bar, nous vous recommandons d'installer un réducteur de pression pour éviter des dommages à la cartouche.

TEMPERATURA DI ESERCIZIO / WORKING TEMPERATURE

max. 70 °C
max. 158 °F

Le portate indicate sono alla pressione consigliata di 3 bar
The indicated flow rates are at the recommended pressure of 3 bar

AERATORE IN DOTAZIONE / AERATOR INCLUDED

Aeratore / Aerator
5 l/min / 1.3 gpm

ceadesign.it

1

2

3

! Irruvidire la filettatura. Applicare il filo sigillaraccordi con pretensione incrociando e seguendo la rotazione del filetto
Slightly roughen the thread. Wind the prestressed sealing cord onto the first pitches clockwise and cross over the threads

PULIZIA / CLEANING / SAUBEKEIT / LIMPIEZA / NETTOYAGE

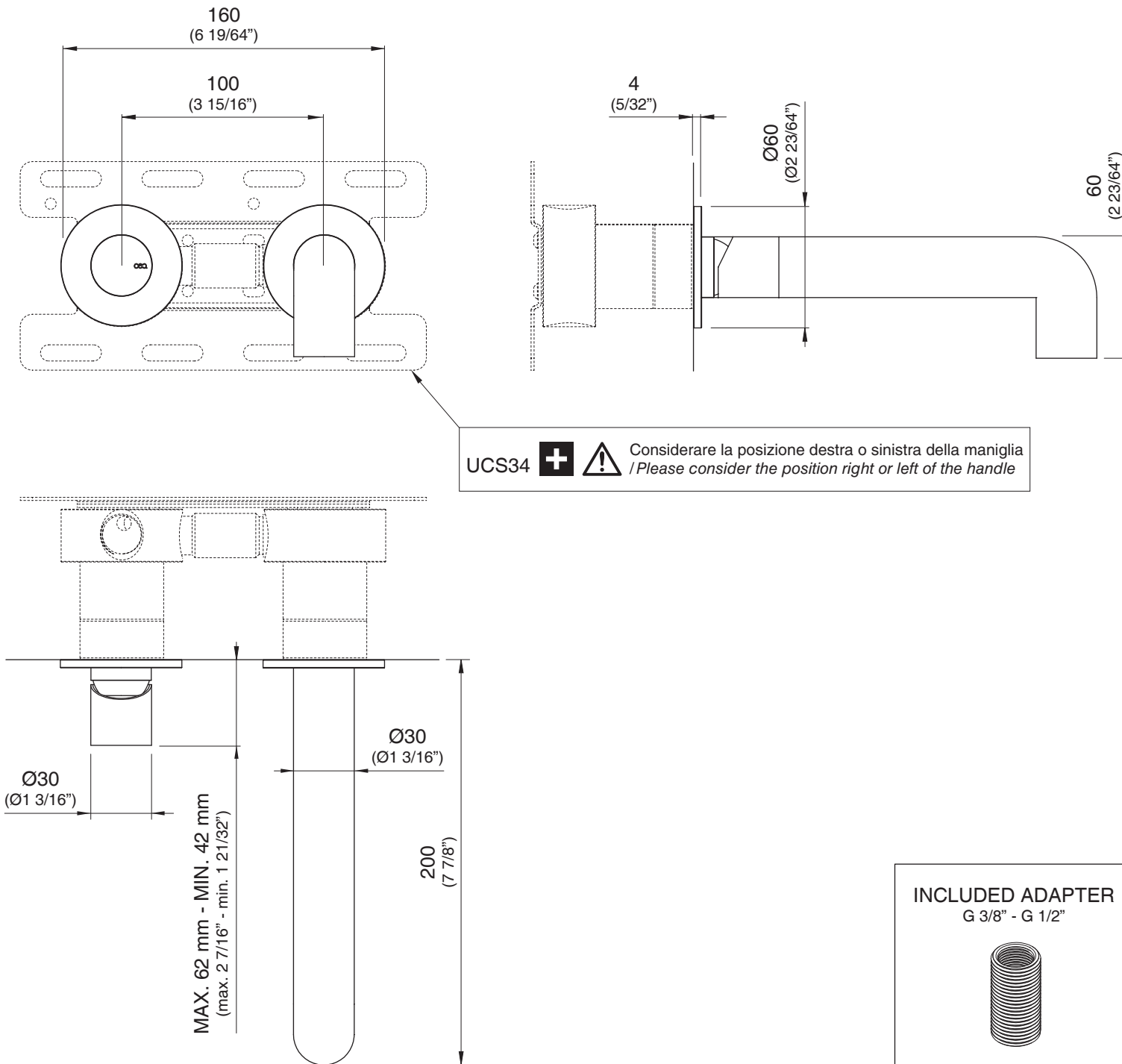

CAR10

_REV1.1



CAR10/CARTESIO

AISI 316/L STAINLESS STEEL

Miscelatore a parete con bocca di erogazione

Wall mounted mixer with spout

CMP DESIGN



Portata aeratore 5 l/min / 1.3 gpm, risparmio idrico
Flow rate aerator 5 l/min / 1.3 gpm, water saving

Prodotto che necessita di parte incasso
Product that needs built-in part

Staffa ausiliaria per cartongesso / fibrogesso
Auxiliary bracket for plasterboard / fiber-board structures

MANUTENZIONE / MAINTENANCE

NON UTILIZZARE DO NOT USE		acido clorico e muriatico chloric and muriatic acid
		acido fluoridrico hydrofluoric acid
		ipoclorito di sodio chlorine bleach
UTILIZZARE TO USE		sapone a PH neutro neutral PH soap

INCLUDED ADAPTER
G 3/8" - G 1/2"



Questi disegni sono proprietà di CEADESIGN SRL s.u. pertanto non potranno essere utilizzati e/o comunicati a terzi, anche in forma parziale, senza preventiva autorizzazione. CEADESIGN SRL s.u. si riserva il diritto di apportare modifiche ai disegni al fine di migliorare il prodotto.

CEADESIGN SRL s.u. has the property rights on these drawings, therefore they cannot be used and/or transferred to third party, even in partial form, without any prior authorization. Furthermore CEADESIGN SRL s.u. reserves the right to apply any change to these drawings in order to upgrade the product.

CEA

ceadesign.it

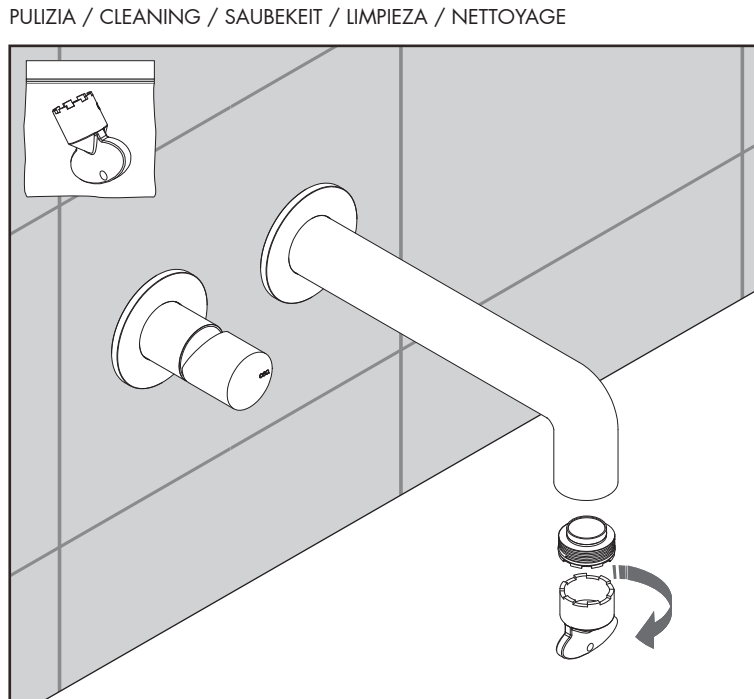
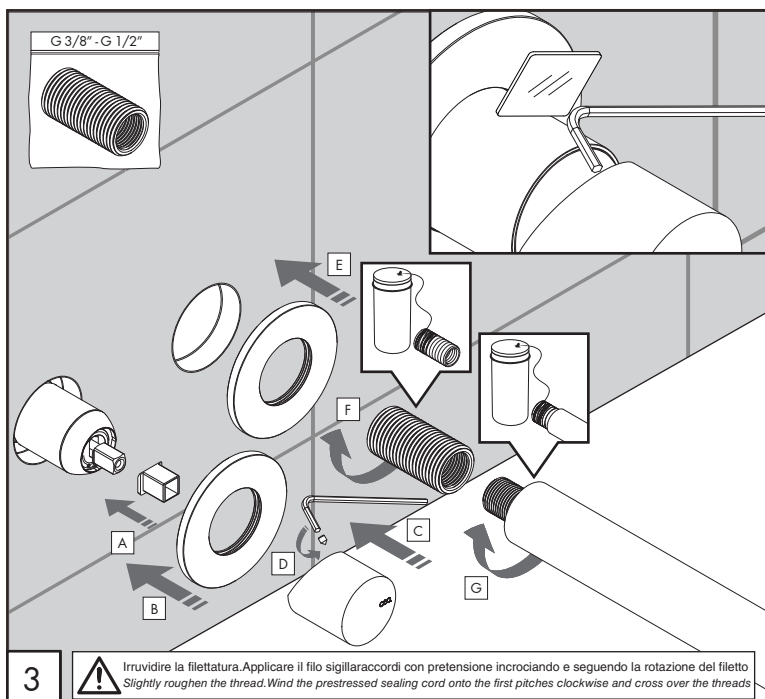
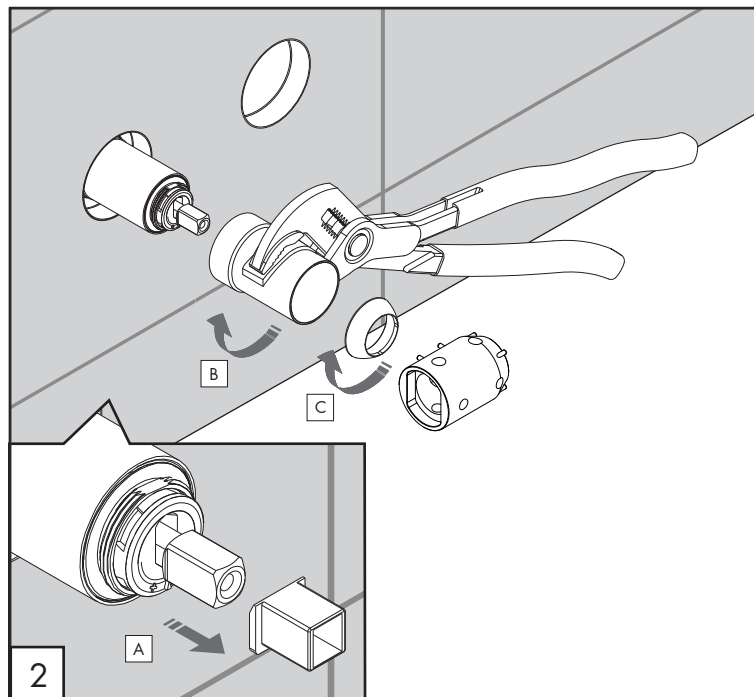
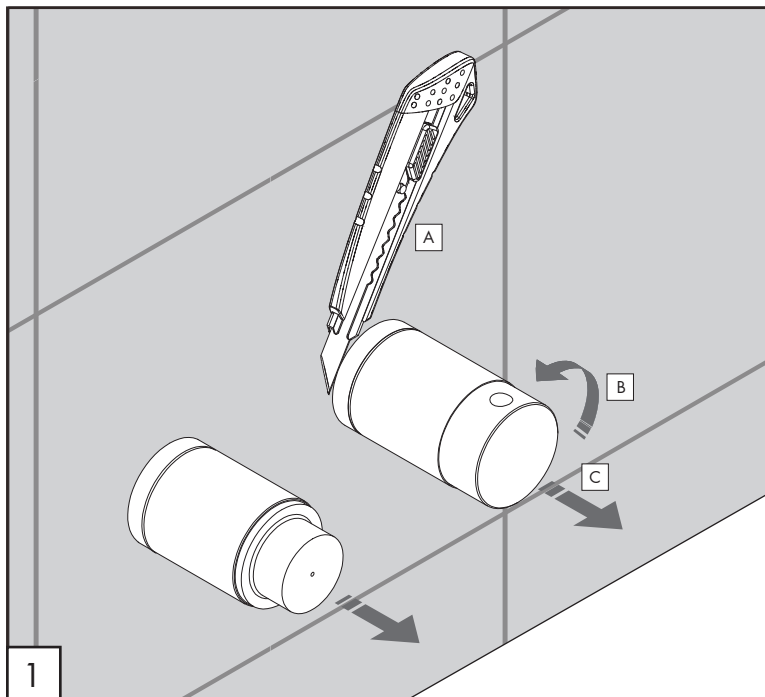

CAR10

_REV1.1



AVVERTENZE TECNICHE

Risciacquare bene le tubazioni prima del montaggio ed evitare sbalzi di pressione fra i raccordi d'acqua fredda e d'acqua calda. In caso di pressioni statiche superiori a 5 bar si raccomanda l'installazione di un riduttore di pressione per evitare danni alla cartuccia.

TECHNICAL WARNINGS

The pipes have to be rinsed thoroughly before installation. Avoid pressure differences between hot and cold water supply. Use of a pressure reducer when static pressure is higher than 5 bar to avoid damage of the cartridge.

TECHNISCHE WARNUNG

Spülen Sie die Leitungen vor dem Einbau und verhindern Sie Wasserdruckwechsel zwischen kalt und warm Wasserverbindungen. Wenn Wasserdruck größer als 5 bar ist, bitte reduzieren Sie den Systemdruck, um Beschädigung der Kartusche zu verhindern.

ADVERTENCIA TÉCNICA

Los tubos tienen que ser enjuagados a fondo antes de la instalación. Evitar grandes diferencias de presión entre las conexiones de agua caliente y fría. En caso de presión estática mayor de 5 bar, se recomienda el uso de un adaptador de presión para evitar daños en el cartucho.

ADVERTISSEMENTS TECHNIQUES

Rincer les tuyaux avant l'installation. Eviter des grandes différences de pression entre l'eau froide et chaude. En cas de pressions statique de plus de 5 bar, nous vous recommandons d'installer un réducteur de pression pour éviter des dommages à la cartouche.

TEMPERATURA DI ESERCIZIO / WORKING TEMPERATURE

max. 70 °C
 max. 158 °F

Le portate indicate sono alla pressione consigliata di 3 bar
The indicated flow rates are at the recommended pressure of 3 bar

AERATORE IN DOTAZIONE / AERATOR INCLUDED

Aeratore / Aerator
 5 l/min / 1.3 gpm

CEQ

3

Irruvidire la filettatura. Applicare il filo sigillaraccordi con preensione incrociando e seguendo la rotazione del filetto.
Slightly roughen the thread. Wind the prestressed sealing cord onto the first pitches clockwise and cross over the threads.

PULIZIA / CLEANING / SAUBEKEIT / LIMPIEZA / NETTOYAGE

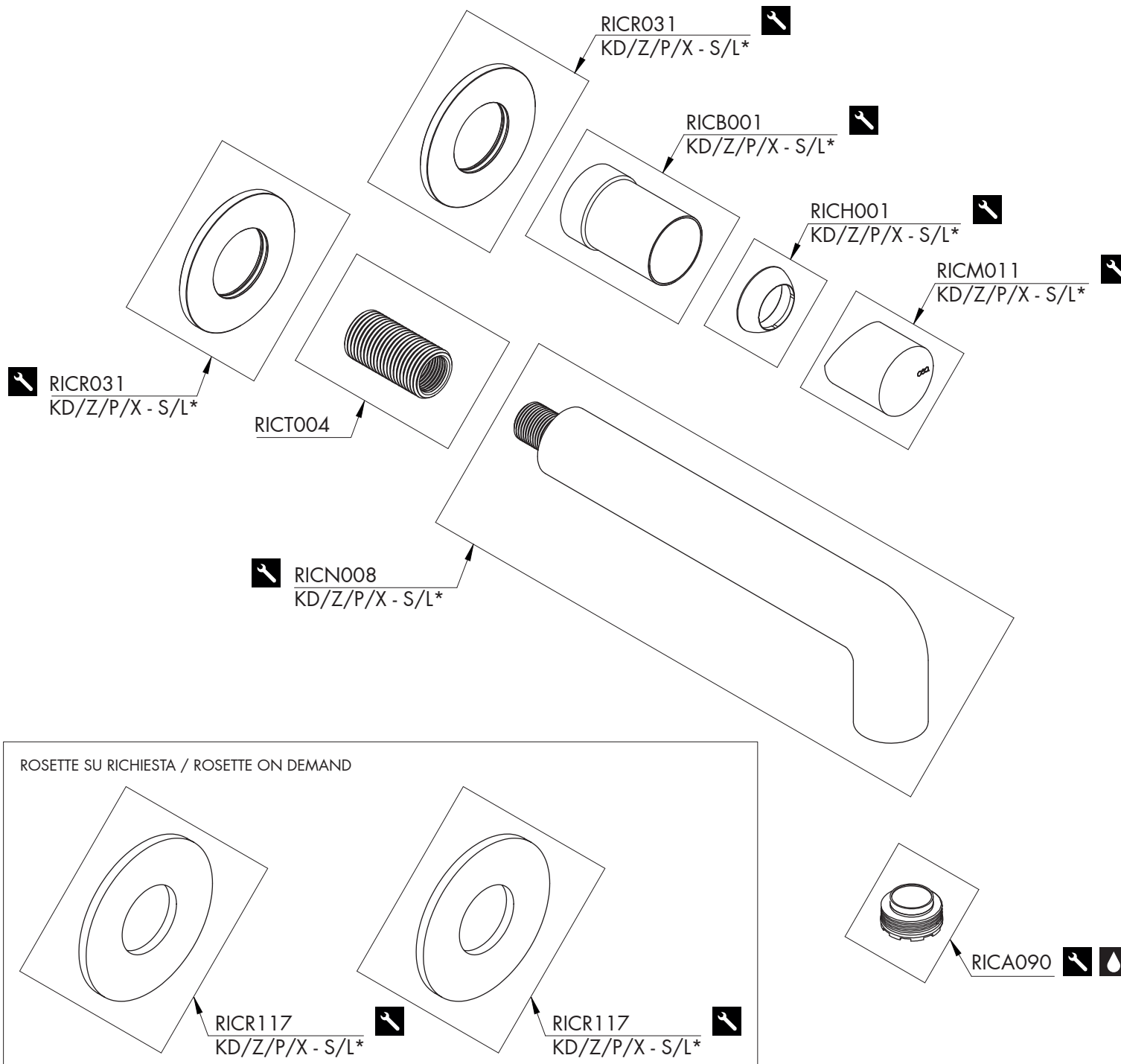

RICAMBI / SPARE PARTS

RICA090	Aeratore / Aerator	5 l/min / 1.3 gpm
RICB001	Carter / Carter	
RICH001	Ghiera / Sleeve	
RICM011	Maniglia / Handle	
RICN008	Bocca di erogazione / Spout	
RICR031	Rosetta / Rosette	
RICT004	Raccordo / Fitting	

ROSETTE SU RICHIESTA / ROSETTE ON DEMAND

RICR117	Rosetta Ø esterno 70 mm Rosette external Ø 70 mm
---------	---

⚠ Conservare gli strumenti inclusi nel prodotto e utilizzati per l'installazione perchè riutilizzabili per i ricambi.
Please, keep the tools included in the item pack and employed for its installation, to re-used them for the spare parts.



Die Werkzeuge, die Sie für die Installation des Produktes benutzt haben, bitte aufbewahren, da sie auch für die Installation der Ersatzteile benutzt werden können.

No tirar las herramientas incluidas en el producto y usadas durante la instalación puesto que se pueden reutilizar para los recambios.

Veuillez conserver les outils inclus dans la boîte du produit et employés pour son installation, parce que réutilisables pour les pièces de rechange.

LEGENDA / LEGEND

ICONE / ICONS

-  Aeratore a risparmio idrico, utilizzabile per lavabo
Water saving aerator, suitable for wash-basin
-  Utensile incluso nel ricambio
Tool included in spare part

FINITURE / FINISHES

- *S finitura satinata / satin finish
- L finitura lucidata / polished finish

FINITURE SPECIALI / SPECIAL FINISHES

- KD black diamond
- Z bronzo / bronze
- P rame / copper
- X light gold