

Devon&Devon

KENSINGTON 172

PIEDE MODELLO: DECÒ
FOOT MODEL: DECÒ

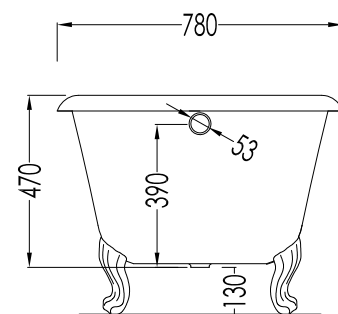
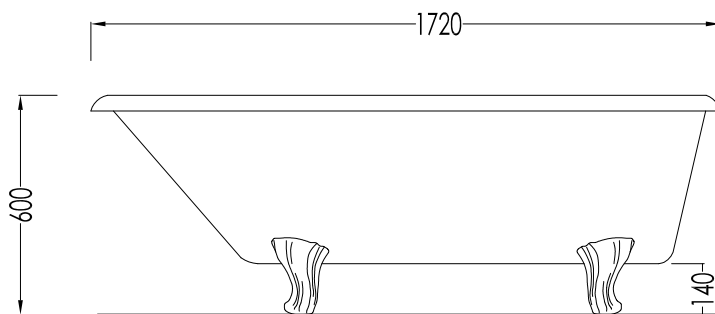
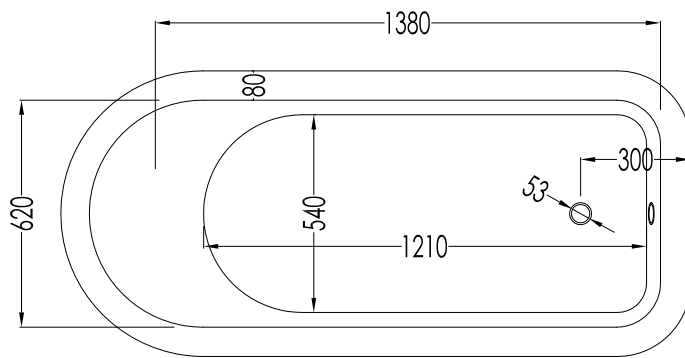

2MRKENS PDALDD; 2MRKENS PDCRDD; 2MRKENS PDOTDD; 2MRKENS PDBIDD

- ▶ VASCA (SENZA FORI) CON PIEDI MODELLO DECÒ
- ▶ VASCA:
 - MATERIALE: ghisa
- ▶ FINITURA PIEDI: alluminio naturale, alluminio lucido, ottone lucido, smalto bianco
- ▶ TOLLERANZA: $\pm 2\%$
- ▶ DIMENSIONE IMBALLO: mm 2000x900x1000 H
- ▶ PESO NETTO: 166 Kg
- ▶ PESO LORDO: 196 Kg
- ▶ VOLUME: 170 L

N.B. Tutte le misure sono in millimetri. Questo disegno è di proprietà Devon&Devon. Non può essere riprodotto o trasmesso a terzi senza autorizzazione.

- ▶ BATHTUB (WITHOUT HOLES) WITH DECÒ MODEL FEET
- ▶ BATHTUB:
 - MATERIAL: cast iron
- ▶ FEET FINISH: natural aluminium, polished aluminium, polished brass, white enamel
- ▶ TOLERANCE: $\pm 2\%$
- ▶ PACKAGING SIZE: mm 2000x900x1000 H
- ▶ NET WEIGHT: 166 Kg
- ▶ GROSS WEIGHT: 196 Kg
- ▶ VOLUME: 170 L

N.B. All measurements are in millimetres. This drawing is property of Devon&Devon. It may not be reproduced or transmitted to third parties without authorization.

Devon&Devon

KENSINGTON 172

PIEDE MODELLO: EAGLE 2
FOOT MODEL: EAGLE 2

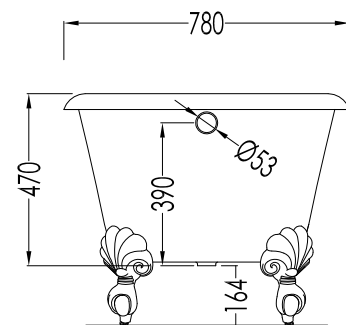
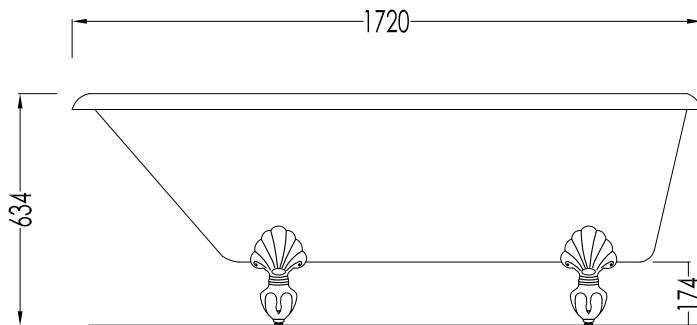
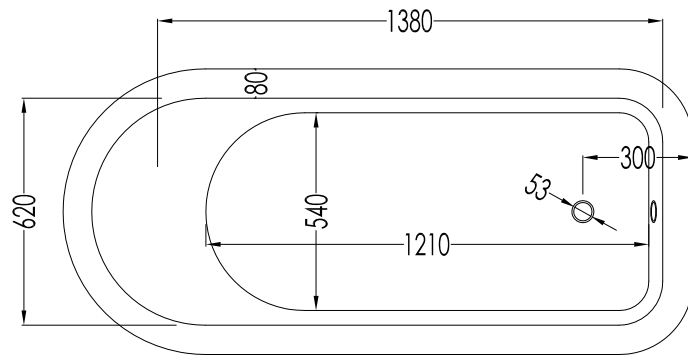
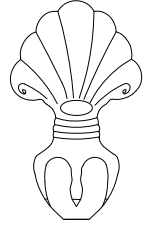

2MRKENSALDD; 2MRKENSQRDD; 2MRKENSOTDD; 2MRKENSIBDD

- ▶ VASCA (SENZA FORI) CON PIEDI MODELLO EAGLE 2
- ▶ VASCA:
 - MATERIALE: ghisa
- ▶ FINITURA PIEDI: alluminio naturale, alluminio lucido, ottone lucido, smalto bianco
- ▶ TOLLERANZA: $\pm 2\%$
- ▶ DIMENSIONE IMBALLO: mm 2000x900x1000 H
- ▶ PESO NETTO: 194 Kg
- ▶ PESO LORDO: 214 Kg
- ▶ VOLUME: 170 L

N.B. Tutte le misure sono in millimetri. Questo disegno è di proprietà Devon&Devon. Non può essere riprodotto o trasmesso a terzi senza autorizzazione.

- ▶ BATHTUB (WITHOUT HOLES) WITH EAGLE 2 MODEL FEET
- ▶ BATHTUB:
 - MATERIAL: cast iron
- ▶ FEET FINISH: natural aluminium, polished aluminium, polished brass, white enamel
- ▶ TOLERANCE: $\pm 2\%$
- ▶ PACKAGING SIZE: mm 2000x900x1000 H
- ▶ NET WEIGHT: 194 Kg
- ▶ GROSS WEIGHT: 214 Kg
- ▶ VOLUME: 170 L

N.B. All measurements are in millimetres. This drawing is property of Devon&Devon. It may not be reproduced or transmitted to third parties without authorization.